

One Piece Unibody Forged Ball Valve - Series 10 Installation, Operation, and Maintenance Instructions

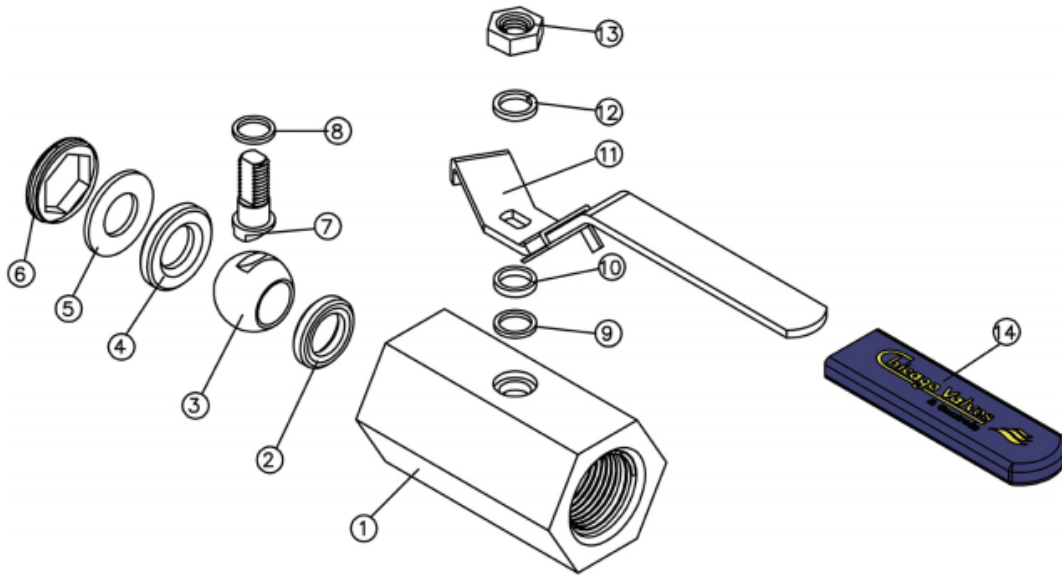

PARTS & MATERIAL

PART NO.	PART NAME	QTY.	MATERIAL
1	Body	1	Forged Steel A105
2	Seat	2	RTFE
3	Ball	1	304 Stainless Steel
4	Washer	1	304 Stainless Steel
5	Seat Retainer	1	304 Stainless Steel
6	Stem	1	304 Stainless Steel
7	Thrust Washer	1	Carbon Fill PTFE
8	Stem Packing	1	PTFE
9	Gland Packing	1	304 Stainless Steel
10	Handle	1	300 Series Stainless Steel
11	Spring Washer	1	300 Series Stainless Steel
12	Handle Nut	1	300 Series Stainless Steel
13	Handle Sleeve	1	PVC

INSTALLATION:

These valves may be installed in the pipeline in any orientation or position, using good piping practice. For threaded end valves, use a suitable joint compound or TFE tape on pipe threads for ease of fit-up.

OPERATION:

These are quarter-turn (90° rotation) ball valves and are normal fitted with a latching lever handle for manual operation. The handles also contain travel stop tabs at the open and closed positions. To open the valve, lift the latch/lock slider up, and turn the handle counterclockwise. To close the valve, lift the latch/lock and turn the handle clockwise.

MAINTENANCE:

----WARNING----
**Do not attempt to perform
maintenance on valves in
pressurized lines.**

Stem Seal Adjustment:

If leakage is evident from the stem packing area, tighten the stem nut 1/8 turn. If the leakage persists, repeat tightening. When leakage cannot be corrected by tightening the stem nut, replacement of the valve will be necessary.